

600V N-Channel Power MOSFET

Features

- High Voltage: $BV_{DSS}=600V(\text{Min.})$
- $I_D : 4A$
- Robust high voltage termination
- Avalanche energy specified
- Fast diode recovery time

Application

- Ballast Bridge
- Switch Mode Power Supplier
- Power Factor Correction
- Lighting

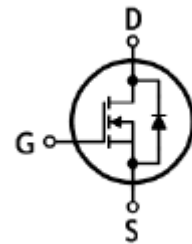
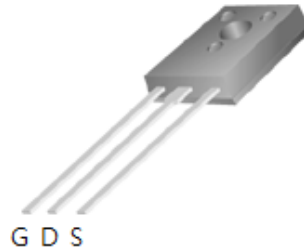

Ordering Information

Type NO	Marking	Package Code
WMM4N60S	4N60M	TO-126F

Absolute maximum ratings ($T_C=25^\circ\text{C}$ unless otherwise noted)

Characteristic	Symbol	Rating	Unit	
Drain-source voltage	V_{DSS}	600	V	
Gate-source voltage	V_{GSS}	± 30	V	
Drain current (DC) *	I_D	$T_C=25^\circ\text{C}$	4.0	A
		$T_C=100^\circ\text{C}$	3.2	A
Drain current (Pulsed) *	I_{DM}	16	A	
Single avalanche energy ②	E_{AS}	86.7	mJ	
Repetitive avalanche current ①	I_{AR}	2.5	A	
Repetitive avalanche energy ①	E_{AR}	3.2	mJ	
Power dissipation	P_D	48	W	
Junction temperature	T_J	150	$^\circ\text{C}$	
Storage temperature range	T_{stg}	-55~150	$^\circ\text{C}$	

* Limited by maximum junction temperature

Characteristic	Symbol	Typ.	Unit	
Thermal resistance	Junction-case	$R_{th(J-C)}$	1.67	$^\circ\text{C}/\text{W}$
	Junction-ambient	$R_{th(J-A)}$	62.5	

Electrical Characteristics ($T_C=25^\circ\text{C}$ unless otherwise noted)

Characteristic	Symbol	Test Condition	Min.	Typ.	Max.	Unit
Drain-source breakdown voltage	BV_{DSS}	$I_D=250\ \mu\text{A}, V_{GS}=0\text{V}$	650	-	-	V
Gate threshold voltage	$V_{GS(th)}$	$I_D=250\ \mu\text{A}, V_{DS}=V_{GS}$	2.0	-	4.0	V
Drain-source cut-off current	I_{DSS}	$V_{DS}=600\text{V}, V_{GS}=0\text{V}, T_C=25^\circ\text{C}$	-	-	1	μA
		$V_{DS}=480\text{V}, V_{GS}=0\text{V}, T_C=125^\circ\text{C}$	-	-	100	μA
Gate leakage current	I_{GSS}	$V_{DS}=0\text{V}, V_{GS}=\pm 20\text{V}$	-	-	± 10	μA
Drain-source on-resistance	$R_{DS(on)}$	$V_{GS}=10\text{V}, I_D=2\text{A}$	-	2.0	2.5	Ω
Forward transfer conductance ③	g_{fs}	$V_{DS}=15\text{V}, I_D=2\text{A}$	-	3.5	-	S
Input capacitance	C_{iss}	$V_{DS}=25\text{V}, V_{GS}=0\text{V}$ $f=1\ \text{MHz}$	-	550	-	pF
Output capacitance	C_{oss}		-	53	-	
Reverse transfer capacitance	C_{rss}		-	2.5	-	
Turn-on delay time ③④	$t_{d(on)}$	$V_{DD}=300\text{V}, I_D=4\text{A}$ $R_G=10\ \Omega$	-	13	-	ns
Rise time ③④	t_r		-	14	-	
Turn-off delay time ③④	$t_{d(off)}$		-	31	-	
Fall time ③④	t_f		-	8.5	-	
Total gate charge ③④	Q_g	$V_{DD}=480\text{V}, V_{GS}=10\text{V}$ $I_D=4\text{A}$	-	14	-	nC
Gate-source charge ③④	Q_{gs}		-	2.8	-	
Gate-drain charge ③④	Q_{gd}		-	5.8	-	

Source-Drain Diode Ratings and Characteristics ($T_C=25^\circ\text{C}$ unless otherwise noted)

Characteristic	Symbol	Test Condition	Min	Typ	Max	Unit
Source current (DC)	I_S	Integral reverse diode in the MOSFET	-	-	4.0	A
Source current (Pulsed)	I_{SM}		-	-	16.0	
Forward voltage	V_{SD}	$V_{GS}=0\text{V}, I_{SD}=4\text{A}$	-	-	1.5	V
Reverse recovery time ③④	t_{rr}	$I_{SD}=4\text{A}, V_{GS}=0\text{V}$	-	250	-	ns
Reverse recovery charge ③④	Q_{rr}	$dI_F/dt=100\text{A}/\mu\text{s}$	-	1.20	-	μC

Note ;

1. Repetitive rating : Pulse width limited by safe operating area
2. $L=10\text{mH}, I_{AS}=4\text{A}, V_{DD}=50\text{V}, R_G=25\ \Omega$, Starting $T_J=25^\circ\text{C}$
3. Pulse Test : Pulse width $\leq 300\ \mu\text{s}$, Duty cycle $\leq 2\%$
4. Essentially independent of operating temperature typical characteristics

Electrical Characteristic Curves

Fig. 1 Typical Output Characteristics

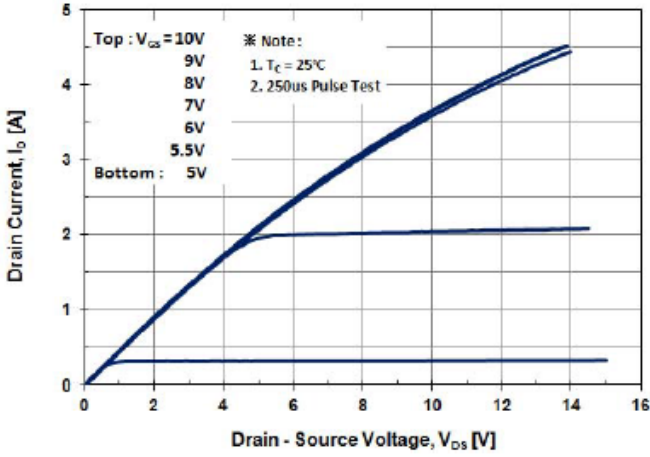

Fig. 2 Typical Output Characteristics

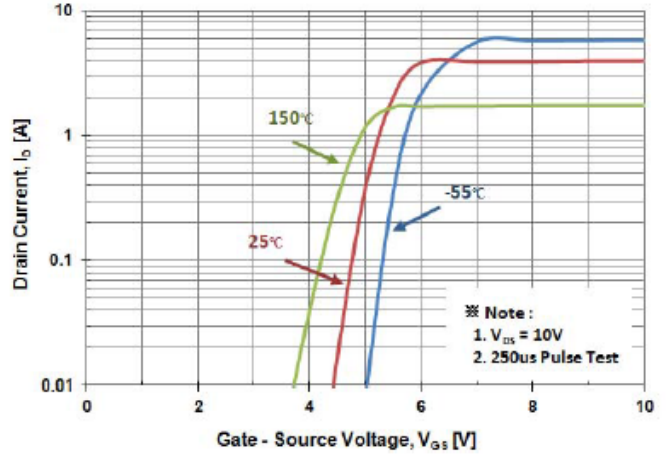

Fig.3 On-Resistance Variation with Drain Current and Gate Voltage

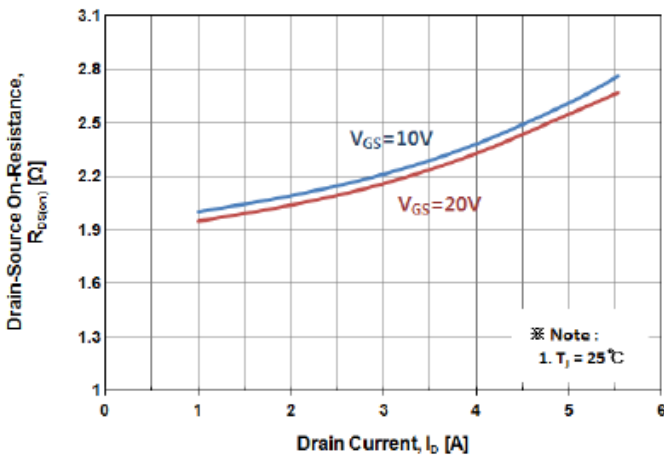

Fig. 4 Body Diode Forward Voltage Variation with Source Current

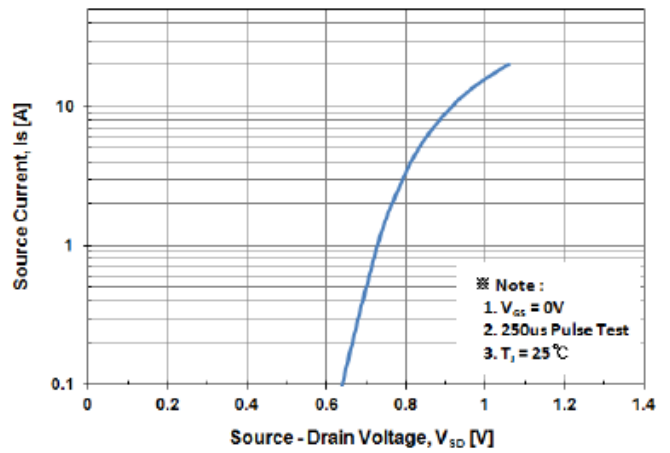

Fig. 5 Typical Capacitance Characteristics

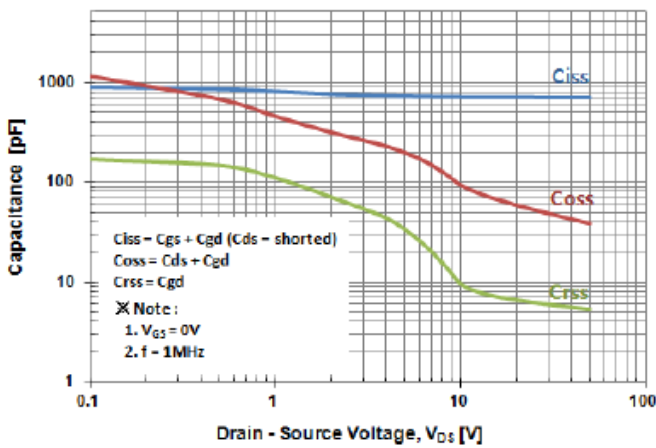
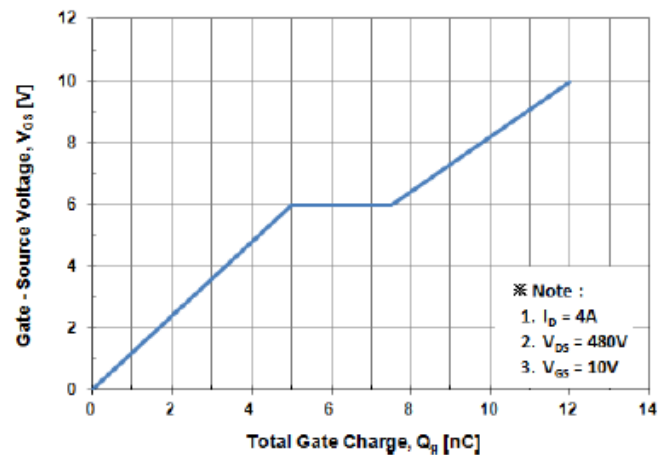

Fig. 6 Typical Total Gate Charge Characteristics



Electrical Characteristic Curves

Fig. 7 Breakdown Voltage Variation vs. Temperature

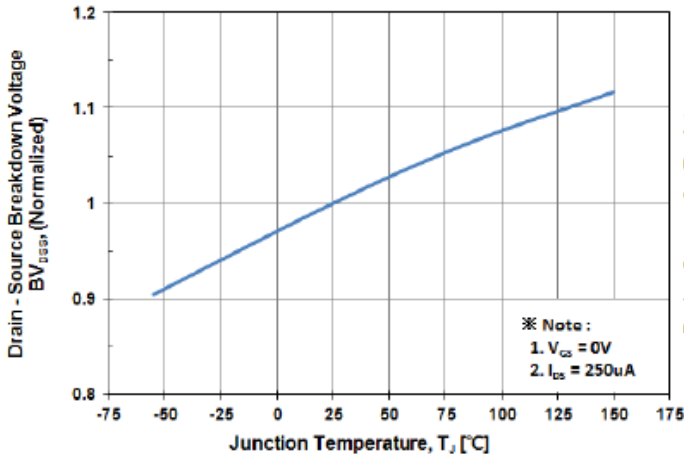

Fig. 8 On-Resistance Variation vs. Temperature

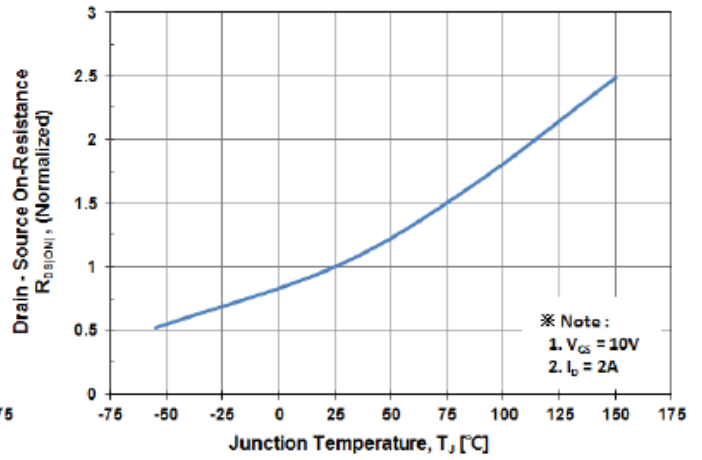

Fig. 9 Maximum Drain Current vs. Case Temperature

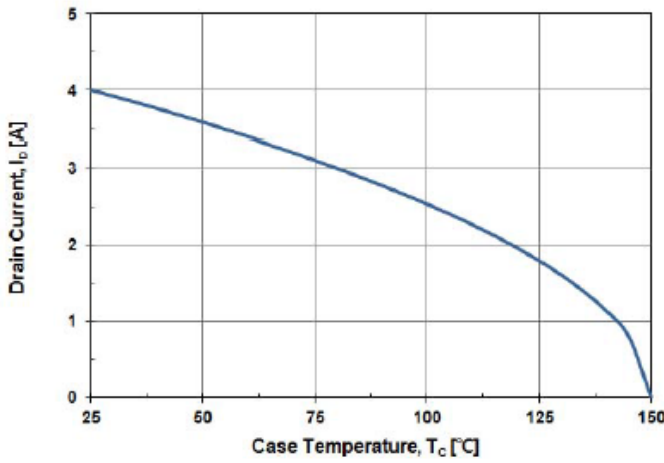

Fig. 10 Maximum Safe Operating Area

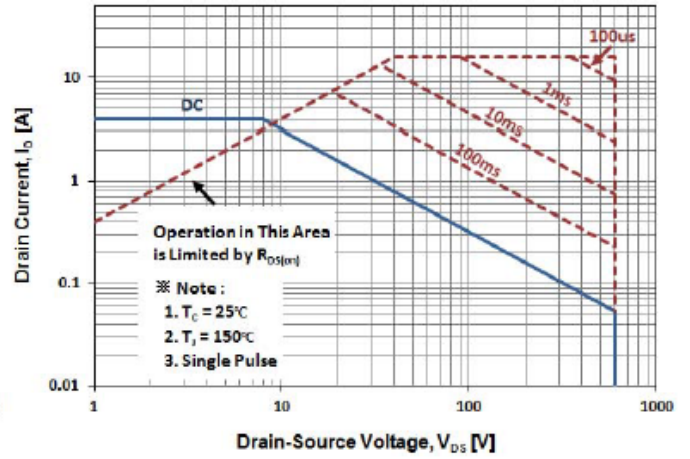
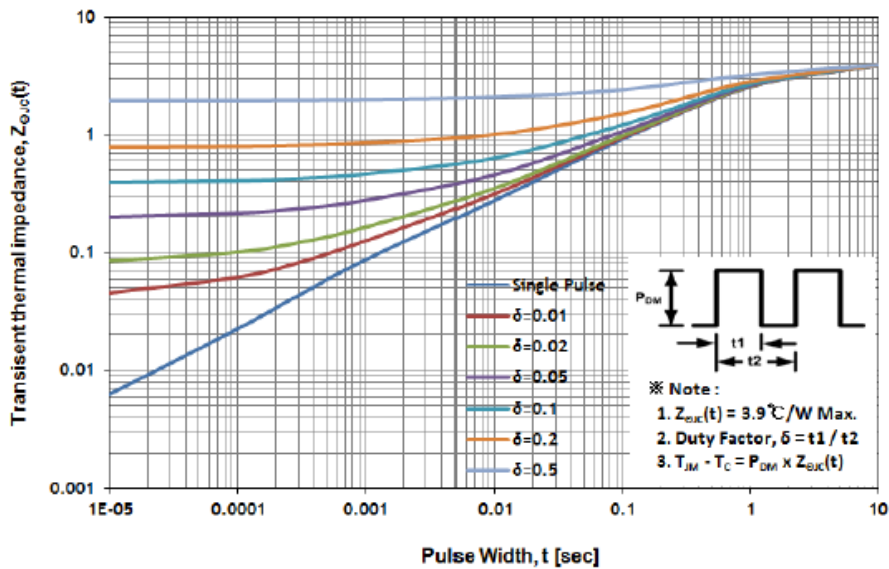
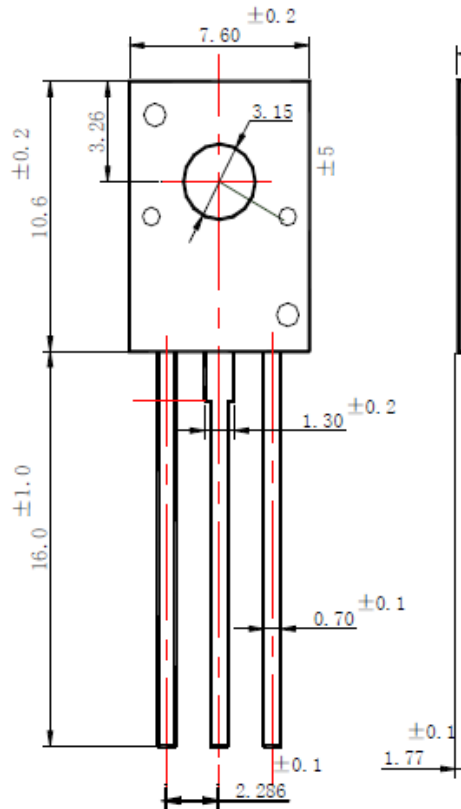

Fig. 11 Transient Thermal Impedance



Outline Dimension : TO-126F



Unit : mm

Marking Diagram

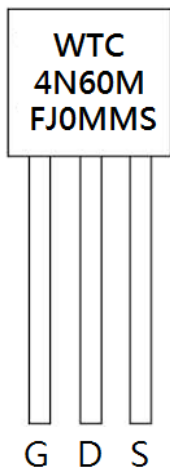

First Line	WTC	Company Name	
Second Line	4N60M	Product Code	
Third Line	FJ0MMS	1st (Year Code)	A-2010 B-2011 C-2012 ...
		2nd (Month Code)	A-Jan B-Feb C-Mar D-Apr E-May F-Jun G-Jul H-Aug I-Sep J-Oct K-Nov L-Dec
		3rd (Lot Code)	0-1 , A-9
		4th (Product Code)	M-MOS , T-Transistor
		5th (Package Code)	M-TO-126F
		6th (Spec Code)	(Reserve)