

High Voltage NPN Transistor

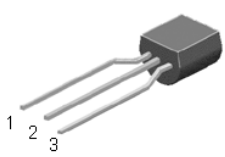

TO-92

Pin Definition

1. Emitter
2. Collector
3. Base

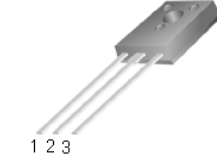

TO-126

Pin Definition

1. Emitter
2. Collector
3. Base

INTERNAL SCHMATIC DIAGRAM

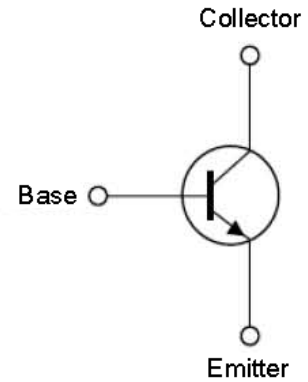

Features

- High Voltage
- Very High Switch Speed
- $BV_{CEO} : 400V$
- $BV_{CBO} : 800V$
- $I_C : 1.5A$
- $V_{CE(SAT)} : 2V@I_C / I_B=800mA / 200mA$
- Silicon Triple Diffused Type

Application

- Electronic Ballasts
- Adapter
- Lighting

ABSOLUTE MAXIMUM RATINGS ($T_c = 25^{\circ}C$)

Parameter	Symbol	Rating	Unit
Collector-Base Voltage	VCBO	800	V
Collect-Break Down Voltage	VCES	800	V
Collector-Emitter Voltage	VCEO	400	V
Emitter-Base Voltage	VEBO	9	V
Collector Current(DC)	IC	1.5	A
Collector Current(Pulse)	ICP	2	A
Total Power Dissipation(TO92)	PD	1.5	W
Total Power Dissipation(TO126)		20	
Junction Temperature	TJ	150	$^{\circ}C$
Operating Junction and Storage Temperature Range	TSTG	-55 ~ +150	$^{\circ}C$

ELECTRICAL CHARACTERISTICS (T_c = 25°C)

Parameter	Symbol	Test Condition	Min	Typ	Max	Unit
Collector-Base Voltage	BVCBO	IC = 1mA, IB=0	800	—	—	V
Collector-Emitter Breakdown Voltage	BVCEO	IC = 1mA, IE=0	400	—	—	V
Emitter- Base Breakdown Voltage	BVEBO	IE = 1mA, IC=0	9	—	—	V
Collector Cutoff Current	ICBO	VCB = 700V, IE=0	—	—	1	μA
Emitter Cutoff Current	IEBO	VEB = 9V, IC=0	—	—	1	μA
DC Current Gain	hFE1	VCE = 10V, IC=10mA	20	—	—	
	hFE2	VCE = 10V, IC=100mA	25	—	45	
	hFE3	VCE = 10V, IC=280mA	20	—	—	
Collector-Emitter Saturation Voltage	VCE(SAT1)	IC/IB = 50mA / 10mA	—	—	0.5	V
	VCE(SAT2)	IC/IB = 100mA / 10mA	—	—	1	
	VCE(SAT3)	IC/IB = 200mA / 20mA	—	—	3	
Base-Emitter Saturation Voltage	VBE(SAT1)	IC/IB = 50mA / 10mA	—	—	1.15	V
	VBE(SAT2)	IC/IB = 100mA / 10mA	—	—	1.25	

Dynamic

Frequency	f _r	VCE=10V, IC=0.1A	4	—	—	MHz
Output Capacitance	Cob	VCB=10V, f=01.MHz	—	21	—	pF

Resistive Load Switching Time (Ratings)

Rise Time	t _r	V _{cc} =125V, IC=100mA,	—	—	2	μS
Storage Time	t _{STG}	IB1 = IB2 = 20mA, tp = 25μS	—	5	6	μS
Fall Time	t _f	Duty Cycle ≤ 1%	—	0.2	0.7	μS

Thermal Performance

Parameter	Symbol	Limit	Unit
Junction to Ambient Thermal Resistance (TO92)	R _{θJA}	122	°C/W
Junction to Ambient Thermal Resistance (TO126)		90	

Electrical Characteristic Curves

Static Characteristics

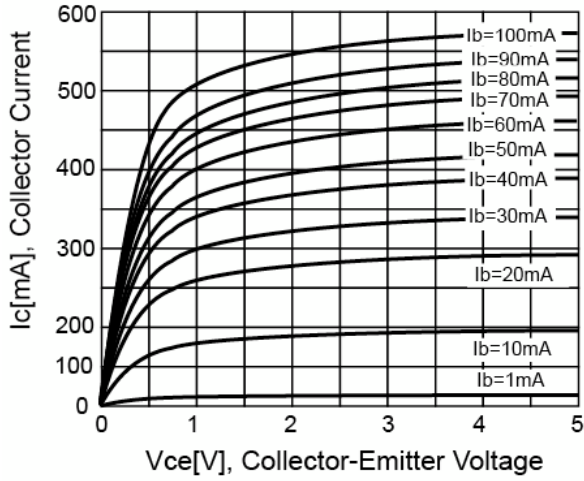

DC Current Gain

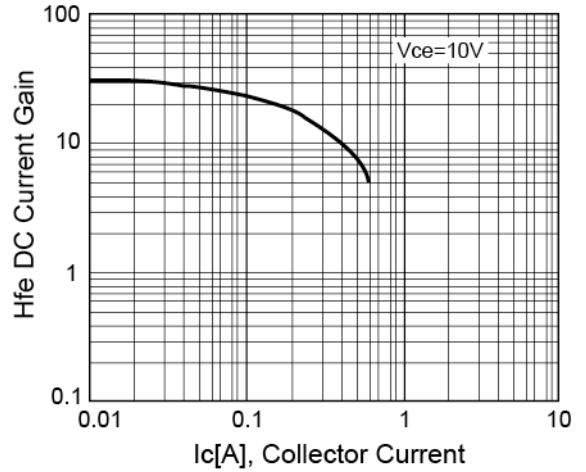

$V_{CE(SAT)}$ v.s. $V_{BE(SAT)}$

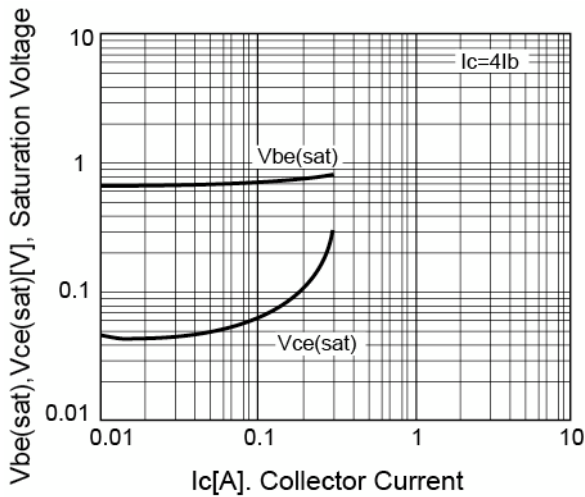

Power Derating

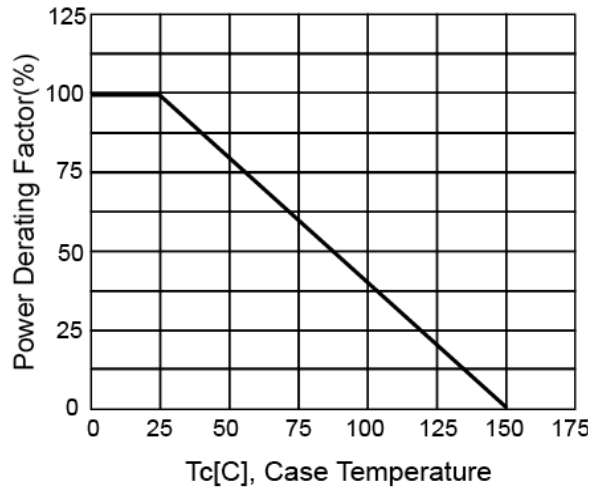

Reverse Bias SOA

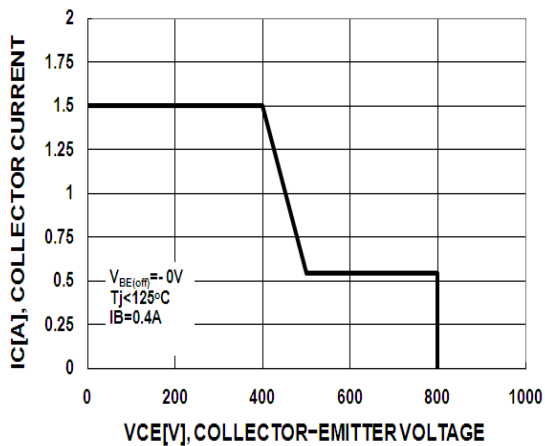

Safety Operating Area

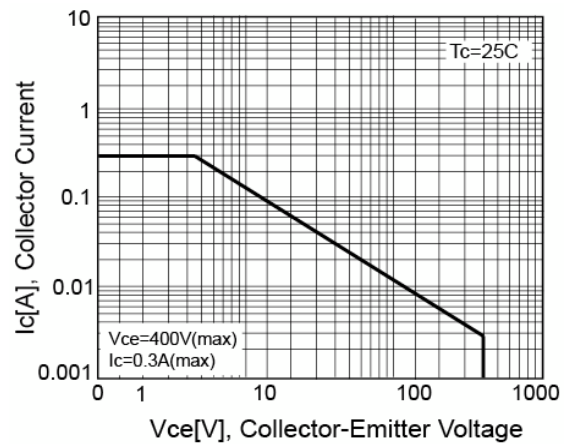

Ordering Information

Type NO	Marking	Package Code
WTBV46	BV46	TO-92

Marking and Pin Define

First Line	WTC	Company Name	
Second Line	BV46	Product Code	
Third Line	A J 0 T L	1st (Year Code)	A-2010 B-2011 C-2012 ...
		2nd (Month Code)	A-Jan, B-Feb, C-Mar, D-Apr, E-May, F-Jun, G-Jul, H-Aug, I-Sep, J-Oct, K-Nov, L-Dec
		3rd (Lot Code)	0~9 , A~Z
		4th (Product Code)	M - MOS , T - Transistor, L - Linear
		5th (Package Code)	I - TO251, D - TO252 , L - TO92, M - TO126, X - TO220, F - TO220F, Y - SOT89, S - SOP8
		6th (Spec Code)	(Reserve)

TO-92 Package Dimension

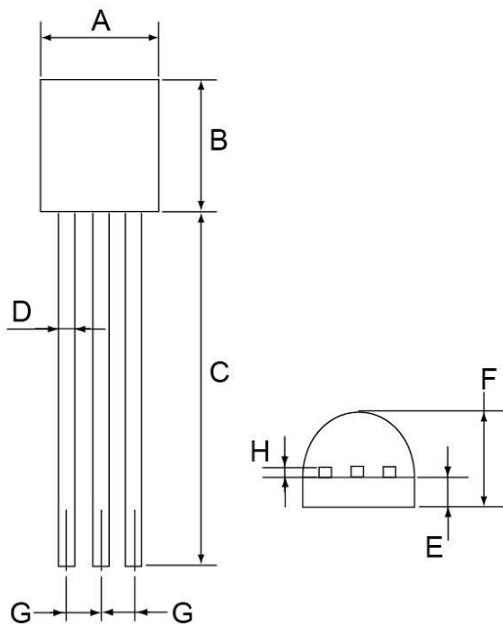

DIM	TO-92 DIMENSION			
	MILLIMETERS		INCHES	
	MIN	MAX	MIN	MAX
A	4.3	4.7	0.169	0.185
B	4.3	4.7	0.169	0.185
C	13.53(typ)		0.532(typ)	
D	0.39	0.49	0.015	0.019
E	1.18	1.28	0.046	0.5
F	3.3	3.7	0.13	0.146
G	1.27	1.31	0.05	0.051
H	0.33	0.43	0.013	0.017

Unit : mm

Ordering Information

Type NO	Marking	Package Code
WTBV46M	BV46M	TO-126

Marking and Pin Define

First Line	WTC	Company Name	
Second Line	BV46M	Product Code	
Third Line	A J 0 T M	1st (Year Code)	A-2010 B-2011 C-2012 ...
		2nd (Month Code)	A-Jan, B-Feb, C-Mar, D-Apr, E-May, F-Jun, G-Jul, H-Aug, I-Sep, J-Oct, K-Nov, L-Dec
		3rd (Lot Code)	0~9, A~Z
		4th (Product Code)	M - MOS, T - Transistor, L - Linear
		5th (Package Code)	I - TO251, D - TO252, L - TO92, M - TO126, X - TO220, F - TO220F, Y - SOT89, S - SOP8
		6th (Spec Code)	(Reserve)

TO-126 Package Dimension

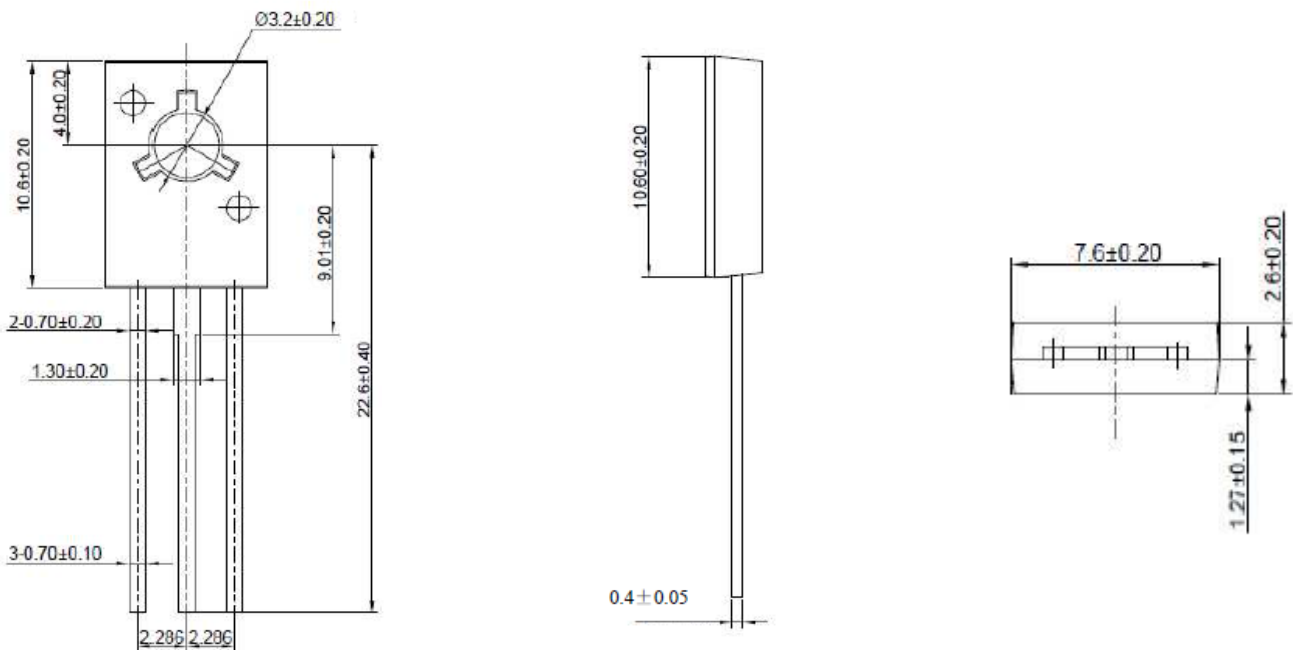

Unit : mm