

High Voltage NPN Transistor

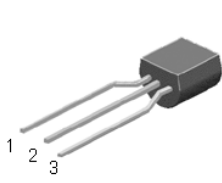

TO-92

Pin Definition

1. Emitter
2. Collector
3. Base

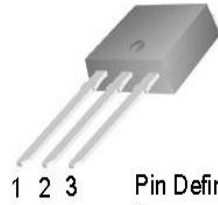

TO-251
Pin Definition
1. Base
2. Collector
3. Emitter

INTERNAL SCHEMATIC DIAGRAM

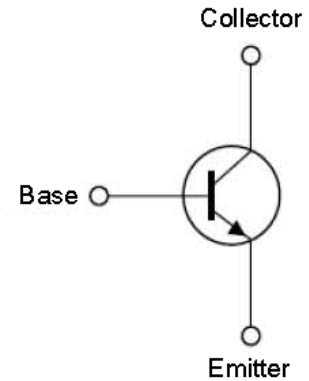

Features

- High Voltage
- High Switch Speed
- $BV_{CEO} : 500V$
- $BV_{CBO} : 850V$
- $I_c : 1.5A$
- $V_{CE(SAT)} : 0.5V@I_c / I_B=0.5A / 0.1A$
- Silicon Triple Diffused Type

Application

- Electronic Ballasts
- Adapter
- Charger
- Lighting

ABSOLUTE MAXIMUM RATINGS ($T_c = 25^\circ C$)

Parameter	Symbol	Max Rating	Unit
Collector-Base Voltage	VCBO	850	V
Collector-Emitter Voltage	VCEO	500	V
Emitter-Base Voltage	VEBO	10	V
Collector Current(DC)	IC	1.5	A
Collector Current(Pulse)	ICP	3	A
Total Power Dissipation(TO92)	Ptot	1.96	W
Total Power Dissipation(TO251)		30	
Junction Temperature	TJ	150	°C
Operating Junction and Storage Temperature Range	TSTG	-55 ~ +150	°C

ELECTRICAL CHARACTERISTICS (T_c = 25°C)

Parameter	Symbol	Test Condition	Min	Typ	Max	Unit
Collector-Base Voltage	BVCBO	IC = 1mA, IB=0	850	—	—	V
Collector-Emitter Breakdown Voltage	BVCEO	IC = 10mA, IE=0	500	—	—	V
Emitter- Base Breakdown Voltage	BVEBO	IE = 1mA, IC=0	9	—	—	V
Collector Cutoff Current	ICBO	VCB = 800V, IE=0	—	—	10	μA
Emitter Cutoff Current	IEBO	VEB = 10V, IC=0	—	—	0.5	μA
DC Current Gain	hFE1	VCE = 10V, IC=10mA	15	—	40	
	hFE2	VCE = 10V, IC=400mA	20	—	40	
	hFE3	VCE = 10V, IC=1A	6	—	40	
Collector-Emitter Saturation Voltage	VCE(SAT1)	IC/IB = 0.5A / 0.1A	—	0.3	0.5	V
	VCE(SAT2)	IC/IB = 1.0A / 0.25A	—	0.5	1	
	VCE(SAT3)	IC/IB = 1.5A / 0.5A	—	0.9	2	
Base-Emitter Saturation Voltage	VBE(SAT1)	IC/IB = 0.5A / 0.1A	—	—	1	V
	VBE(SAT2)	IC/IB = 1.0A / 0.25A	—	—	1.2	

Dynamic

Frequency	f _r	VCE=10V, IC=0.1A	4	—	—	MHz
Output Capacitance	C _{ob}	VCB=10V, f=01.MHz	—	21	—	pF

Resistive Load Switching Time (Ratings)

Delay Time	t _d	V _{cc} =125V, IC=1A, IB1=IB2=0.2A, tp=25uS Duty Cycle ≤ 1%	—	0.05	0.2	uS
Rise Time	t _r		—	1.1	—	uS
Storage Time	t _{STG}		—	2	4	uS
Fall Time	t _f		—	0.4	0.7	uS

*Note:pulse test: pulse width ≤ 300uS, duty cycle ≤ 2%

Electrical Characteristics Curve ($T_a = 25^\circ\text{C}$, unless otherwise noted)

Figure 1. Static Characteristics

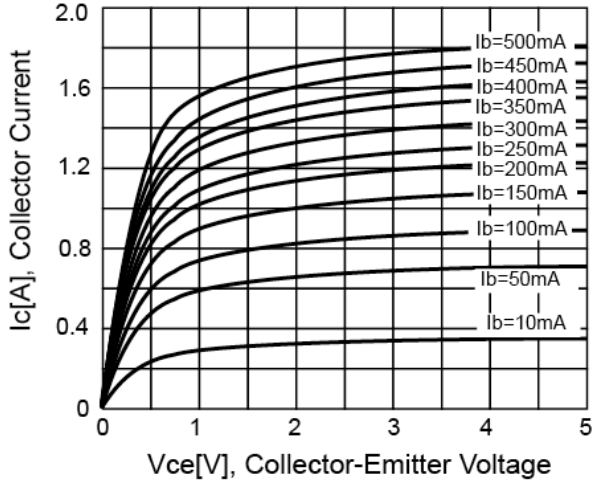

Figure 2. DC Current Gain

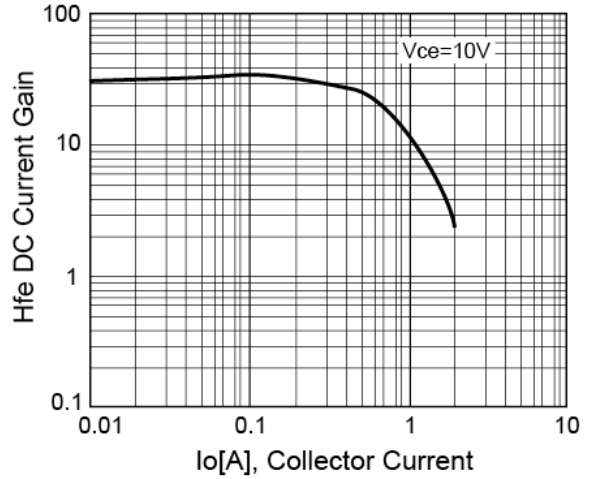

Figure 3. $V_{CE(SAT)}$ v.s. $V_{BE(SAT)}$

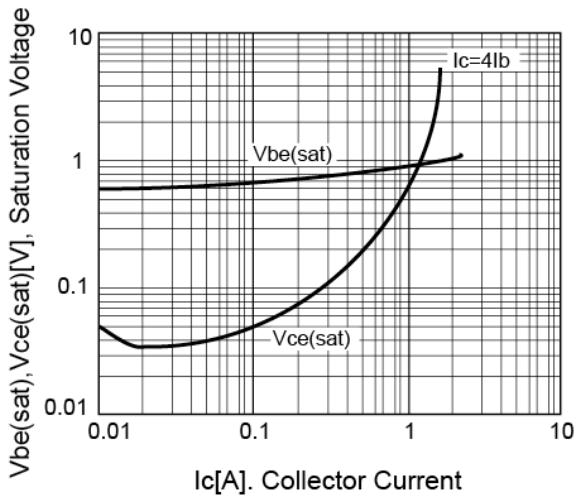

Figure 4. Power Derating

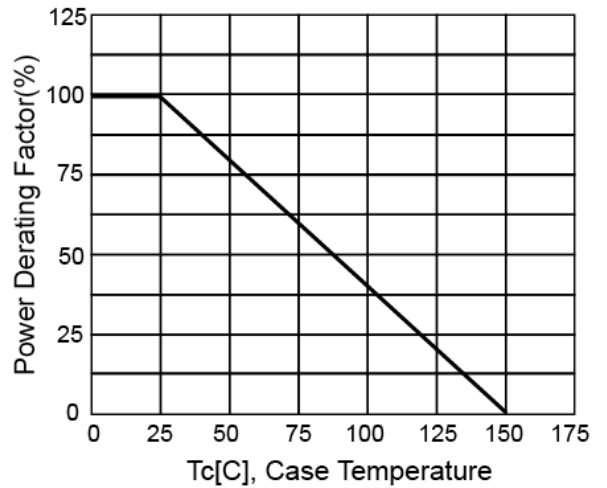

Figure 5. Reverse Bias SOA

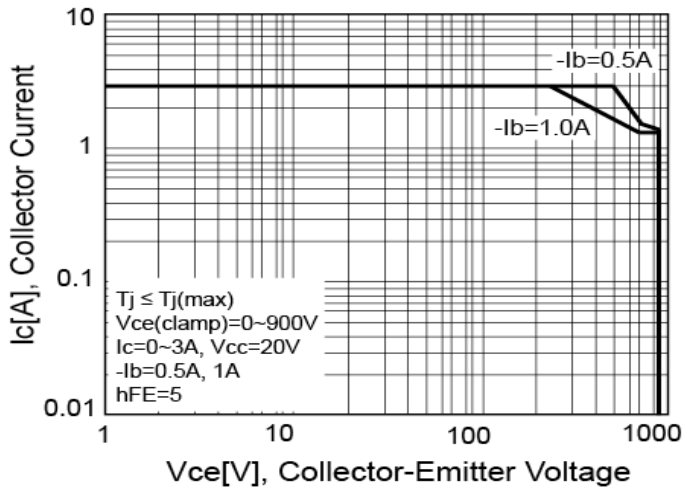
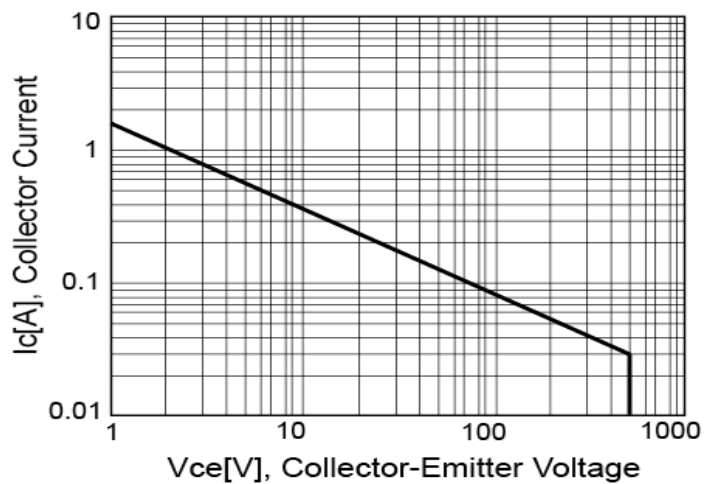

Figure 6. Safety Operating Area



Ordering Information

Type NO	Marking	Package Code
WTBV49SL	BV49SL	TO-92

Marking and Pin Define

First Line	WTC	Company Name	
Second Line	BV49SL	Product Code	
Third Line	<u>B</u> <u>K</u> <u>0</u> <u>T</u> <u>L</u>	1st (Year Code)	A-2010 B-2011 C-2012 ...
		2nd (Month Code)	A-Jan, B-Feb, C-Mar, D-Apr, E-May, F-Jun, G-Jul, H-Aug, I-Sep, J-Oct, K-Nov, L-Dec
		3rd (Lot Code)	0~9 , A~Z
		4th (Product Code)	M - MOS , T - Transistor, L - Linear
		5th (Package Code)	I - TO251, D - TO252 , L - TO92, M - TO126, X - TO220, F - TO220F, Y - SOT89, S - SOP8
		6th (Spec Code)	(Reserve)

TO-92 Package Dimension

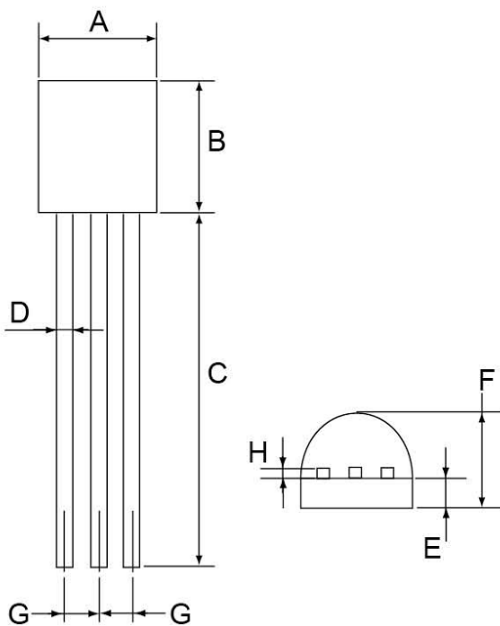

DIM	TO-92 DIMENSION			
	MILLIMETERS		INCHES	
	MIN	MAX	MIN	MAX
A	4.3	4.7	0.169	0.185
B	4.3	4.7	0.169	0.185
C	13.53(typ)		0.532(typ)	
D	0.39	0.49	0.015	0.019
E	1.18	1.28	0.046	0.5
F	3.3	3.7	0.13	0.146
G	1.27	1.31	0.05	0.051
H	0.33	0.43	0.013	0.017

Ordering Information

Type NO	Marking	Package Code
WTI49S	49SI	TO-251

Marking and Pin Define

First Line	WTC	Company Name	
Second Line	49SI	Product Code	
Third Line	A J 0 T M	1st (Year Code)	A-2010 B-2011 C-2012 ...
		2nd (Month Code)	A-Jan, B-Feb, C-Mar, D-Apr, E-May, F-Jun, G-Jul, H-Aug, I-Sep, J-Oct, K-Nov, L-Dec
		3rd (Lot Code)	0~9, A~Z
		4th (Product Code)	M - MOS, T - Transistor, L - Linear
		5th (Package Code)	I - TO251, D - TO252, L - TO92, M - TO126, X - TO220, F - TO220F, Y - SOT89, S - SOP8
		6th (Spec Code)	(Reserve)

TO-251 Package Dimension

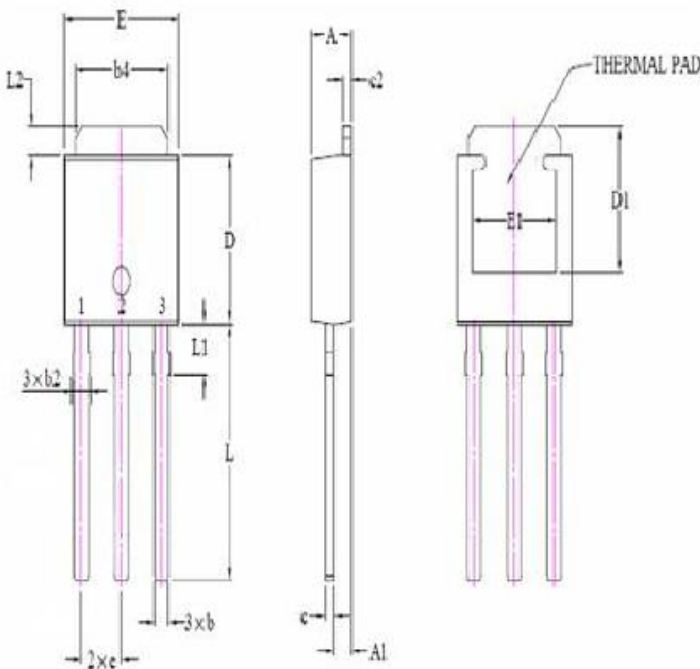

Symbol	TO-251DL			
	Millimeters		Inches	
	Min	Max	Min	Max
A	2.230	2.420	0.087	0.095
A1	0.890	1.140	0.035	0.045
b	0.550	0.670	0.022	0.026
b2	0.760	0.950	0.030	0.038
b4	5.200	5.400	0.205	0.213
c	0.450	0.570	0.018	0.023
c2	0.450	0.550	0.018	0.022
D	5.950	6.250	0.234	0.246
D1	4.200	4.500	0.165	0.177
E	5.400	5.700	0.212	0.224
E1	4.750	4.850	0.187	0.191
e	2.28 REF		0.090 REF	
L	8.900	9.500	0.350	0.374
L1	1.900	2.290	0.075	0.090
L2	0.900	1.000	0.035	0.039